

## (Weak) Implicative hyper BCK-ideals

*Radjab A. Borzooei and M. Bakhshi*

### Abstract

In this manuscript first we define the notion of weak implicative hyper *BCK*-ideal of a hyper *BCK*-algebra. Then we state and prove some theorems which determine the relationship among this notion and (weak, commutative, (strong) implicative) hyper *BCK*-ideals, positive implicative hyper *BCK*-ideals of type 1, 3, ..., 8 and (strong) positive implicative hyper *BCK*-ideals. Specially, we prove that if  $H = \{0, a, b, c\}$  is a hyper *BCK*-algebra of order 4, such that  $a \circ x = \{0\}$ , for all  $0 \neq x \in H$  and  $I$  is a hyper *BCK*-ideal and weak implicative hyper *BCK*-ideal of  $H$ , then  $I$  is a positive implicative hyper *BCK*-ideal of type 3.

### 1. Introduction

The study of *BCK*-algebras was initiated by Y. Imai and K. Iséki [7] in 1966 as a generalization of the concept of set-theoretic difference and propositional calculi. Since then a great deal of literature has been produced on the theory of *BCK*-algebras. In particular, emphasis seems to have been put on the ideal theory of *BCK*-algebras. The hyperstructure theory (called also multialgebras) was introduced in 1934 by F. Marty [13] at the 8th congress of Scandinavian Mathematiciens. Around the 40's, several authors worked on hypergroups, especially in France and in the United States, but also in Italy, Russia and Japan. Over the following decades, many important results appeared, but above all since the 70's onwards the most luxuriant flourishing of hyperstructures has been seen. Hyperstructures have many applications to several sectors of both pure and applied sciences. In [12], Y. B. Jun et al. applied the hyperstructures to *BCK*-algebras, and introduced the notion of a hyper *BCK*-algebra which is a

---

2000 Mathematics Subject Classification: 06F35, 03G25

Keywords: hyper *BCK*-algebra, (weak) implicative hyper *BCK*-ideal, positive implicative hyper *BCK*-ideals of types 1,3,...,8

generalization of *BCK*-algebra, and investigated some related properties. They also introduced the notion of a hyper *BCK*-ideal and a weak hyper *BCK*-ideal and gave relations between hyper *BCK*-ideals and weak hyper *BCK*-ideals. Y. B. Jun et al. [12] gave a condition for a hyper *BCK*-algebra to be a *BCK*-algebra. In [2], R. A. Borzooei and M. Bakhshi introduced the notions of positive implicative hyper *BCK*-ideals of types 1, 2, ..., 8 and gave relations between these notions and (weak, strong) hyper *BCK*-ideals. They also in [1], introduced the concept of commutative hyper *BCK*-ideals of types 1, 2, 3 and 4 and give some relations among these notions and positive implicative hyper *BCK*-ideals of types 1, 2, ..., 8 and (weak) hyper *BCK*-ideals and state its characterizations. In [8], Y. B. Jun et al. introduced the notion of implicative hyper *BCK*-ideals and gave some relations between this notion and hyper *BCK*-ideals. Now, in this paper we introduce the concept of weak implicative hyper *BCK*-ideal and we study some related properties. Moreover, we give some relations among (weak) hyper *BCK*-ideal, (weak) implicative hyper *BCK*-ideal, positive implicative hyper *BCK*-ideals of types 1, 2, ..., 8 and commutative hyper *BCK*-ideals of types 1, 2, 3 and 4, under suitable conditions.

## 2. Preliminaries

**Definition 2.1.** By a *hyper BCK-algebra* we mean a non-empty set  $H$  endowed with a hyperoperation “ $\circ$ ” and a constant 0 satisfying the following axioms:

- (HK1)  $(x \circ z) \circ (y \circ z) \ll x \circ y$ ,
- (HK2)  $(x \circ y) \circ z = (x \circ z) \circ y$ ,
- (HK3)  $x \circ H \ll \{x\}$ ,
- (HK4)  $x \ll y$  and  $y \ll x$  imply  $x = y$ ,

for all  $x, y, z \in H$ , where  $x \ll y$  is defined by  $0 \in x \circ y$  and for every  $A, B \subseteq H$ ,  $A \ll B$  is defined by  $\forall a \in A, \exists b \in B$  such that  $a \ll b$ . In such case, we call “ $\ll$ ” the *hyperorder* in  $H$ .

**Example 2.2.** (i) Define a hyperoperation “ $\circ$ ” on  $H = [0, \infty)$  by

$$x \circ y = \begin{cases} [0, x] & \text{if } x \leq y \\ (0, y) & \text{if } x > y \neq 0 \\ \{x\} & \text{if } y = 0 \end{cases}$$

for all  $x, y \in H$ . Then  $H$  is a hyper *BCK*-algebra.

(ii) Let  $H = \{0, a, b, c\}$ . Consider the following table:

$\circ$	0	a	b	c
0	{0}	{0}	{0}	{0}
a	{a}	{0}	{0}	{0}
b	{b}	{b}	{0}	{0}
c	{c}	{c}	{c}	{0, c}

Then  $H$  is a hyper BCK-algebra.

**Proposition 2.3.** [12] *In any hyper BCK-algebra  $H$ , the following hold:*

- (i)  $x \circ 0 = \{x\}$ ,
  - (ii)  $x \circ y \ll x$ ,
  - (iii)  $0 \circ A = \{0\}$ ,
  - (iv)  $A \ll A$ ,
  - (v)  $A \subseteq B$  implies  $A \ll B$ ,
  - (vi)  $A \circ \{0\} = \{0\}$  implies  $A = \{0\}$ ,
- for all  $x, y, z \in H$  and for all non-empty subsets  $A$  and  $B$  of  $H$ .

Let  $I$  be a non-empty subset of a hyper BCK-algebra  $H$  and  $0 \in I$ . Then  $I$  is said to be a *strong hyper BCK-ideal* of  $H$  if  $(x \circ y) \cap I \neq \emptyset$  and  $y \in I$  implies that  $x \in I$ , *hyper BCK-ideal* of  $H$  if  $x \circ y \ll I$  and  $y \in I$  imply  $x \in I$ , *weak hyper BCK-ideal* of  $H$  if  $x \circ y \subseteq I$  and  $y \in I$  imply  $x \in I$ , *hyper BCK-subalgebra* of  $H$  if  $x \circ y \subseteq I$  for all  $x, y \in I$ , *reflexive* if  $x \circ x \subseteq I$ , for all  $x \in H$ , *positive implicative hyper BCK-ideal of type 1* if  $(x \circ y) \circ z \subseteq I$  and  $y \circ z \subseteq I$  imply  $x \circ z \subseteq I$ , *positive implicative hyper BCK-ideal of type 3* if  $(x \circ y) \circ z \ll I$  and  $y \circ z \ll I$  imply  $x \circ z \subseteq I$ , *commutative hyper BCK-ideal of type 1* if  $(x \circ y) \circ z \subseteq I$  and  $z \in I$  imply  $x \circ (y \circ (y \circ x)) \subseteq I$ , *commutative hyper BCK-ideal of type 3* if  $(x \circ y) \circ z \ll I$  and  $z \in I$  imply  $x \circ (y \circ (y \circ x)) \subseteq I$ , for all  $x, y, z \in H$ . It is easy to see that any positive implicative hyper BCK-ideal of type 3 and commutative hyper BCK-ideal of type 3 (positive implicative hyper BCK-ideal of type 1 and commutative hyper BCK-ideal of type 1) is a (weak) hyper BCK-ideal, any (strong) hyper BCK-ideal is a (hyper BCK-ideal) weak hyper BCK-ideal and a hyper BCK-subalgebra of  $H$ . Moreover, any reflexive hyper BCK-ideal of  $H$  is a strong hyper BCK-ideal of  $H$ .

**Theorem 2.4.** [1, 2] *Let  $I$  be a non-empty subset of hyper BCK-algebra  $H$ . Then,*

- (i) *if  $I$  is a positive implicative hyper BCK-ideal of type 3 (type 1), then  $I$  and  $I_a$  are (weak) hyper BCK-ideals of  $H$ , where for all  $a \in H$ ,*

$$I_a = \{x \in H : x \circ a \subseteq I\}$$

- (ii) if  $H$  is a positive implicative hyper BCK-algebra (that is, for all  $x, y, z \in H$ ,  $(x \circ y) \circ z = (x \circ z) \circ (y \circ z)$ ) and  $I$  is a (weak) hyper BCK-ideal of  $H$ , then  $I$  is a positive implicative hyper BCK-ideal of type 3 (type 1),
- (iii) if  $I$  is a commutative hyper BCK-ideal of type 3 (type 1), then  $I$  is a (weak) hyper BCK-ideal of  $H$ .

**Lemma 2.5.** [1, 9] Let  $A$ ,  $B$  and  $I$  are non-empty subsets of hyper BCK-algebra  $H$ . Then,

- (i) if  $I$  is a hyper BCK-ideal of  $H$ , then  $A \ll I$  implies  $A \subseteq I$ ,
- (ii) if  $I$  is a hyper BCK-ideal of  $H$ , then  $A \circ B \ll I$  and  $B \subseteq I$  imply  $A \subseteq I$ ,
- (iii) if  $I$  is a weak hyper BCK-ideal of  $H$ , then  $A \circ B \subseteq I$  and  $B \subseteq I$  imply  $A \subseteq I$ ,
- (iv) if  $I$  is a reflexive hyper BCK-ideal of  $H$  and for  $x, y \in H$ ,  $(x \circ y) \cap I \neq \emptyset$ , then  $x \circ y \ll I$ .

### 3. Weak implicative hyper BCK-ideals

From now on in this paper, we let  $H$  denote a hyper BCK-algebra.

**Definition 3.1.** Let  $I$  be a non-empty subset of  $H$  and  $0 \in I$ . Then  $I$  is called a *weak implicative hyper BCK-ideal* of  $H$  if,  $(x \circ z) \circ (y \circ x) \subseteq I$  and  $z \in I$  imply  $x \in I$ , for all  $x, y, z \in H$ .

**Example 3.2.** Let  $H$  be hyper BCK-algebra which is defined in Example 2.2 (ii). Then,  $I_1 = \{0, a, b\}$  is a weak implicative hyper BCK-ideal of  $H$ , but  $I_2 = \{0, a\}$  is not a weak implicative hyper BCK-ideal. Since we have  $(b \circ 0) \circ (c \circ b) = b \circ c = \{0\} \subseteq I$  and  $0 \in I$  but  $b \notin I$ .

**Theorem 3.3.** Let  $I$  be a non-empty subset of  $H$ . Then,  $I$  is a weak implicative hyper BCK-ideal of  $H$  if and only if  $I$  is a weak hyper BCK-ideal of  $H$  and  $x \circ (y \circ x) \subseteq I$  implies  $x \in I$ , for all  $x, y \in H$ .

*Proof.* Let  $I$  be a weak implicative hyper BCK-ideal of  $H$ ,  $x \circ y \subseteq I$  and  $y \in I$ , for  $x, y \in H$ . Since  $(x \circ y) \circ (0 \circ x) = x \circ y \subseteq I$  and  $y \in I$  then  $x \in I$  and so  $I$  is a weak hyper BCK-ideal of  $H$ . Now, let  $x \circ (y \circ x) \subseteq I$ , for  $x, y \in H$ . Then by Proposition 2.3(i),  $(x \circ 0) \circ (y \circ x) = x \circ (y \circ x) \subseteq I$ . Since  $0 \in I$  and  $I$  is a weak implicative hyper BCK-ideal of  $H$ , then  $x \in I$ . Conversely, let  $I$  be a weak hyper BCK-ideal of  $H$  and for all  $x, y \in H$ ,  $x \circ$

$(y \circ x) \subseteq I$  implies that  $x \in I$ . Now, let  $(x \circ z) \circ (y \circ x) \subseteq I$  and  $z \in I$ , for  $x, y, z \in H$ . Then by (HK2),  $(x \circ (y \circ x)) \circ z = (x \circ z) \circ (y \circ x) \subseteq I$ . Since  $I$  is a weak hyper BCK-ideal of  $H$  and  $z \in I$ , then by Lemma 2.5(iii) we get that  $x \circ (y \circ x) \subseteq I$  and so by hypothesis  $x \in I$ . Therefore,  $I$  is a weak implicative hyper BCK-ideal of  $H$ .  $\square$

**Example 3.4.** Let  $H$  be hyper BCK-algebra which is defined in Example 2.2(ii). Then,  $I = \{0, a\}$  is a weak hyper BCK-ideal of  $H$ , but it is not a weak implicative hyper BCK-ideal of  $H$ . Since  $b \circ (c \circ b) = b \circ c = \{0\} \subseteq I$  but  $b \notin I$ .

**Theorem 3.5.** Let  $H = \{0, a, b\}$  be a hyper BCK-algebra of order 3. Then, proper subset  $I$  of  $H$  is a weak hyper BCK-ideal of  $H$  if and only if  $I$  is a weak implicative hyper BCK-ideal of  $H$ .

*Proof.* ( $\Leftarrow$ ) The proof follows by Theorem 3.3.

( $\Rightarrow$ ) The only proper weak hyper BCK-ideals of  $H$  are  $I = \{0, a\}$  or  $I = \{0, b\}$ . Let  $I = \{0, a\}$  be a weak hyper BCK-ideal of  $H$ . By Theorem 3.3, it is enough to show that for all  $x, y \in H$ , if  $x \circ (y \circ x) \subseteq I$  then  $x \in I$ . Let  $x \circ (y \circ x) \subseteq I$  but  $x \notin I$ , for  $x, y \in H$ . Hence,  $x = b$ . Thus,  $b \circ (y \circ b) \subseteq I$  and  $b \notin I$ . Now we consider the following cases for  $y$ .

If  $y = 0$ , then  $\{b\} = b \circ 0 = b \circ (0 \circ b) \subseteq I$ , which is a contradiction. If  $y = a$  and  $a \ll b$ , since  $0 \in a \circ b$  then we get that  $\{b\} = b \circ 0 \subseteq b \circ (a \circ b) \subseteq I$  which is impossible. If  $y = a$  and  $b \ll a$ , then  $H$  satisfies the normal condition and so by Lemma 2.6(iv) of [1],  $a \circ b = \{0\}$  or  $\{0, a\}$ . Hence  $0 \in a \circ b$  and so  $a \ll b$  which is a contradiction. If  $y = a$ ,  $a \not\ll b$  and  $b \not\ll a$ , then  $H$  satisfies the simple condition and so by Lemma 2.6(i) of [1],  $a \circ b = \{a\}$  and  $b \circ a = \{b\}$ . Therefore,  $\{b\} = b \circ a \subseteq b \circ (a \circ b) \subseteq I$ , which is impossible. If  $y = b$ , since  $0 \in b \circ b$  then  $\{b\} = b \circ 0 \subseteq b \circ (b \circ b) \subseteq I$ , which is impossible. Therefore,  $x \in I$  and so  $I$  is a weak implicative hyper BCK-ideal of  $H$ .

Now, let  $I = \{0, b\}$  be a weak hyper BCK-ideal of  $H$  and  $x \circ (y \circ x) \subseteq I$  but  $x \notin I$ . Hence  $x = a$ . Therefore,  $a \circ (y \circ a) \subseteq I$  and  $a \notin I$ . If  $y = 0$  or  $a$ , then by similar way in the proof of case  $I = \{0, a\}$ , we get a contradiction. Now let  $y = b$ . If  $b \ll a$ , then  $0 \in b \circ a$  and so  $\{a\} = a \circ 0 \subseteq a \circ (b \circ a) = a \circ (y \circ a) \subseteq I$ , which is impossible. If  $a \ll b$ , then  $H$  satisfies the normal condition. Hence by Lemma 2.6(b) of [1],  $a \circ b = \{0\}$  or  $\{0, a\}$  and  $b \circ a = \{a\}$  or  $\{b\}$  or  $\{a, b\}$ . If  $b \circ a = \{b\}$  or  $\{a, b\}$ , then  $a \circ b \subseteq a \circ (b \circ a) \subseteq I$ . Since  $b \in I$  and  $I$  is a weak hyper BCK-ideal of  $H$ , then  $a \in I$  which is a contradiction. Thus  $b \circ a = \{a\}$ . If  $a \circ b = \{0\}$ , then  $a \circ b \subseteq I$  and  $b \in I$ . Since  $I$  is a weak hyper BCK-ideal, then  $a \in I$ , which is impossible. Hence,  $a \circ b = \{0, a\}$ . By

Lemma 2.6(iii) of [1],  $a \circ a = \{0\}$  or  $\{0, a\}$ . If  $a \circ a = \{0, a\}$ , since  $b \circ a = \{a\}$ , then  $a \in a \circ a = a \circ (b \circ a) = a \circ (y \circ a) \subseteq I$  which is a contradiction. Hence  $a \circ a = \{0\}$ . But in this case by (HK1),  $\{0, a\} = (a \circ b) \circ (a \circ b) \ll a \circ a = \{0\}$  and so  $a \ll 0$ , which is impossible.

If  $b \not\ll a$  and  $a \not\ll b$ , then  $H$  satisfies the simple condition and so by Lemma 2.6(a) of [1],  $a \circ b = \{a\}$  and  $b \circ a = \{b\}$ . Hence  $\{a\} = a \circ b = a \circ (b \circ a) = a \circ (y \circ a) \subseteq I$ , which is impossible. Therefore,  $x \in I$  and so  $I$  is a weak implicative hyper  $BCK$ -ideal of  $H$ .  $\square$

**Corollary 3.6.** *Let  $H = \{0, a, b\}$  be a hyper  $BCK$ -algebra of order 3 and  $I$  be a non-empty subset of  $H$ . Then,*

- (i)  *$I$  is a weak implicative hyper  $BCK$ -ideal of  $H$  if and only if  $I$  is a positive implicative hyper  $BCK$ -ideal of type 1,*
- (ii)  *$I$  is a weak implicative hyper  $BCK$ -ideal of  $H$  if and only if  $I$  is a commutative hyper  $BCK$ -ideal of type 1.*

*Proof.* (i) The proof follows by Theorem 3.5 and Theorem 3.10(ii) of [1].

(ii) The proof follows from Theorems 3.5 and Theorem 4.6 of [1].  $\square$

**Theorem 3.7.** *Let  $H = \{0, a, b, c\}$  be a hyper  $BCK$ -algebra of order 4 such that  $a \circ x = \{0\}$ , for all  $0 \neq x \in H$  and  $I$  be a proper subset of  $H$ . If  $I$  is a hyper  $BCK$ -ideal and a weak implicative hyper  $BCK$ -ideal of  $H$ , then  $I$  is a positive implicative hyper  $BCK$ -ideal of type 3.*

*Proof.* Let  $I$  be a proper hyper  $BCK$ -ideal and weak implicative hyper  $BCK$ -ideal of  $H$ . Then, there is the following cases for  $I$ ;

$$\{0, a\}, \{0, b\}, \{0, c\}, \{0, a, b\}, \{0, a, c\}, \{0, b, c\}$$

If  $I$  is equal to  $\{0, b\}$  or  $\{0, b, c\}$  (or  $\{0, c\}$ ), since by hypothesis  $a \circ b = (a \circ c) \circ \{0\} \ll I$ ,  $b \in I$  ( $c \in I$ ) and  $I$  is a hyper  $BCK$ -ideal of  $H$ , then  $a \in I$  which is impossible. Now, we consider the following cases for  $I$ ;

- (i)  $I = \{0, a, b\}$ .

Let  $I$  not be a positive implicative hyper  $BCK$ -ideal of type 3, that is  $(x \circ y) \circ z \ll I$  and  $y \circ z \ll I$  but  $x \circ z \not\subseteq I$ . Then,  $c \in x \circ z$  and so by hypothesis and Proposition 2.3(iii),  $x \neq 0, a$ . Since  $I$  is a hyper  $BCK$ -ideal, then by Lemma 2.5(i),  $(x \circ y) \circ z \subseteq I$  and  $y \circ z \subseteq I$ . Hence, by (HK2) we have  $c \circ y \subseteq (x \circ z) \circ y = (x \circ y) \circ z \subseteq I$ . Now, if  $y = 0$  or  $a$  or  $b$ , since  $c \circ y \subseteq I$  and  $y \in I$  then  $c \in I$  which is impossible. If  $y = c$ , then  $c \circ c \subseteq I$  and  $c \circ z = y \circ z \subseteq I$ . Now, if  $z \in \{0, a, b\}$  then  $c \in I$  and so we get a contradiction. Hence  $z = c$ . By above,  $x \neq 0, a$ . If  $x = c$ ,

then  $c \in x \circ z = c \circ c \subseteq I$ , which is impossible. Thus  $x = b$ . By (HK3),  $c \in b \circ c \ll b$  and so  $0 \in c \circ b$ . Hence, by (HK4)  $0 \notin b \circ c$ . Moreover, if  $b \in b \circ c$  then  $c \in b \circ c \subseteq (b \circ c) \circ c = (x \circ y) \circ z \subseteq I$  which is a contradiction. Hence  $b \circ c = \{c\}$  or  $\{a, c\}$ . Since  $c \ll b$ , then  $b \circ c \ll \{0, a, b\} = I$ . Moreover, since  $I$  is a hyper BCK-ideal of  $H$  then by Lemma 2.5(i),  $c \in b \circ c \subseteq I$  which is a contradiction. Therefore,  $I$  is a positive implicative hyper BCK-ideal of type 3.

(ii)  $I = \{0, a, c\}$ .

The proof of this case is nearly similar to the proof of case (i).

(iii)  $I = \{0, a\}$ .

Let  $I$  not be a positive implicative hyper BCK-ideal of type 3, that is  $(x \circ y) \circ z \ll I$  and  $y \circ z \ll I$  but  $x \circ z \not\subseteq I$ . Then,  $(x \circ z) \cap \{b, c\} \neq \emptyset$ . Now we consider the following cases.

Case 1.  $c \in x \circ z$ .

By Lemma 2.5(i),  $(x \circ y) \circ z \subseteq I$  and  $y \circ z \subseteq I$ . By (HK2),  $c \circ y \subseteq (x \circ z) \circ y = (x \circ y) \circ z \subseteq I$ .

Case 1-1. If  $y = 0$  or  $a$ , since  $c \circ y \subseteq I$  and  $y \in I$  and  $I$  is a weak hyper BCK-ideal of  $H$ , then  $c \in I$  which is impossible.

Case 1-2. If  $y = b$ , then we consider the following cases for  $z$ :

Case 1-2-1. If  $z = 0$  or  $a$ , since  $b \circ z = y \circ z \subseteq I$  and  $z \in I$  and  $I$  is a weak hyper BCK-ideal of  $H$ , then  $b \in I$  which is impossible.

Case 1-2-2. If  $z = b$ , then  $c \in x \circ z = x \circ b$ ,  $b \circ b = y \circ z \subseteq I$  and  $c \circ b = c \circ y \subseteq I$ . By hypothesis and Proposition 2.3(iii),  $x \neq 0$  and  $a$ . If  $x = b$ , then  $c \in x \circ b = b \circ b \subseteq I$  which is impossible. If  $x = c$ , then  $c \in x \circ b = c \circ b \subseteq I$  which is impossible.

Case 1-2-3. If  $z = c$ , then  $c \in x \circ c$ ,  $c \circ b = c \circ y \subseteq I$  and  $b \circ c = y \circ z \subseteq I$ . It is clear that  $x \neq 0$  and  $a$ . If  $x = b$ , then  $c \in x \circ c = b \circ c \subseteq I$  which is impossible. If  $x = c$ , then  $c \in x \circ c = c \circ c$ . By (HK1),  $(c \circ c) \circ (b \circ c) \ll c \circ b \subseteq I$  and so  $(c \circ c) \circ (b \circ c) \ll I$ . Hence, by Lemma 2.5(i),  $(c \circ c) \circ (b \circ c) \subseteq I$ . Since  $b \circ c \subseteq I$  and  $I$  is a weak hyper BCK-ideal of  $H$ , then  $c \in c \circ c \subseteq I$ , which is impossible.

Case 1-3. If  $y = c$ , then  $c \circ c \subseteq I$  and  $c \circ z \subseteq I$ . Now, we consider the following cases for  $z$ ;

Case 1-3-1. If  $z = 0$  or  $a$ , since  $c \circ z = y \circ z \subseteq I$  and  $z \in I$  and  $I$  is a weak hyper BCK-ideal of  $H$ , then  $c \in I$  which is impossible.

Case 1-3-2. If  $z = b$ , then  $c \in x \circ z = x \circ b$ ,  $c \circ c = c \circ y \subseteq I$  and  $c \circ b = y \circ z \subseteq I$ . It is clear that  $x \neq 0$  and  $a$ . If  $x = c$ , then  $c \in x \circ b = c \circ b \subseteq I$  which is impossible. Now, we let  $x = b$ . Then

$$c \circ c \subseteq I, \quad c \circ b \subseteq I, \quad (b \circ c) \circ b \subseteq I, \quad c \in b \circ b$$

By (HK3),  $c \in b \circ b \ll b$ . Then  $0 \in c \circ b$  and so  $0 \notin b \circ c$ . Moreover,  $b \notin b \circ c$ . Since if  $b \in b \circ c$ , then  $c \in b \circ b \subseteq (b \circ c) \circ b \subseteq I$ , which is impossible. Hence,  $b \circ c = \{a\}$  or  $\{c\}$  or  $\{a, c\}$ .

Case 1-3-2-1. If  $b \circ c = \{a\}$ , by (HK1),  $(b \circ b) \circ (c \circ b) \ll b \circ c = \{a\} \subseteq I$  and so by Lemma 2.5(i),  $(b \circ b) \circ (c \circ b) \subseteq I$ . Since  $c \circ b \subseteq I$  and  $I$  is a weak hyper *BCK*-ideal of  $H$ , then  $c \in b \circ b \subseteq I$ , which is impossible.

Case 1-3-2-2. If  $b \circ c = \{c\}$ , then  $c \circ (b \circ c) = c \circ c \subseteq (b \circ b) \circ c = (b \circ c) \circ b \subseteq I$ . Since  $I$  is a weak implicative hyper *BCK*-ideal of  $H$ , then by Theorem 3.3,  $c \in I$ , which is impossible.

Case 1-3-2-3. If  $b \circ c = \{a, c\}$ , since  $I$  is a hyper *BCK*-ideal of  $H$ , then it is a hyper *BCK*-subalgebra of  $H$  and so by (HK2), we get that  $(c \circ a) \circ b = (c \circ b) \circ a \subseteq I \circ a \subseteq I$ . If  $b \in c \circ a$ , then  $c \in b \circ b \subseteq (c \circ a) \circ b \subseteq I$ , which is impossible. Moreover, if  $c \circ a \subseteq I$ , since  $a \in I$  and  $I$  is a weak hyper *BCK*-ideal of  $H$ , then  $c \in I$  which is impossible. Hence,  $c \circ a = \{c\}$  or  $\{a, c\}$ . If  $c \circ a = \{a, c\}$ , since  $c \circ c \subseteq I$  then

$$\begin{aligned} (c \circ a) \circ (c \circ a) &= \{a, c\} \circ \{a, c\} = (a \circ a) \cup (a \circ c) \cup (c \circ a) \cup (c \circ c) \\ &= \{0\} \cup \{0\} \cup \{a, c\} \cup (c \circ c) = \{0, a, c\} \end{aligned}$$

Hence, by (HK1),  $\{0, a, c\} = (c \circ a) \circ (c \circ a) \ll c \circ c \subseteq I$ , and so by Lemma 2.5(i),  $\{0, a, c\} \subseteq I$  which is impossible. Therefore,  $c \circ a = \{c\}$ . Now, by (HK2),  $(b \circ a) \circ c = (b \circ c) \circ a = \{a, c\} \circ a = (a \circ a) \cup (c \circ a) = \{0\} \cup \{c\} = \{0, c\}$ . If  $b \in b \circ a$ , then  $\{a, c\} = b \circ c \subseteq (b \circ a) \circ c = \{0, c\}$  which is impossible. Moreover, since  $0 \in \{0\} = a \circ b$ , then  $0 \notin b \circ a$ . Thus,  $b \circ a = \{a\}$  or  $\{c\}$  or  $\{a, c\}$ . If  $b \circ a = \{a\}$ , since  $b \circ a \subseteq I$  and  $a \in I$ , then  $b \in I$  which is impossible. If  $b \circ a = \{c\}$  or  $\{a, c\}$ , then  $c \circ a \subseteq (b \circ b) \circ a = (b \circ a) \circ b \subseteq \{a, c\} \circ b = (a \circ b) \cup (c \circ b) = \{0\} \cup (c \circ b) \subseteq I$ . Since  $a \in I$  and  $I$  is a weak hyper *BCK*-ideal of  $H$ , then  $c \in I$ , which is impossible.

Case 1-3-3. If  $z = c$ , then  $c \in x \circ z = x \circ c$ ,  $c \circ c \subseteq I$ . It is clear that  $x \neq 0$  and  $a$ . If  $x = c$ , then  $c \in x \circ c = c \circ c \subseteq I$  which is impossible.

Now, let  $x = b$ . Hence

$$c \in b \circ c, \quad (b \circ c) \circ c \subseteq I, \quad c \circ c \subseteq I$$

Since  $I$  is a hyper *BCK*-subalgebra of  $H$ , then by (HK2),  $(c \circ a) \circ c = (c \circ c) \circ a \subseteq I \circ a \subseteq I$ . Now, by similar way to the proof of Case 1-3-2-3, we can prove that  $c \circ a = \{c\}$ . Also, since  $c \in b \circ c \ll b$ , then  $0 \notin b \circ c$ . Moreover, if  $b \in b \circ c$ , then  $c \in b \circ c \subseteq (b \circ c) \circ c \subseteq I$  which is impossible. Thus,  $b \circ c = \{c\}$  or  $\{a, c\}$ . If  $b \circ c = \{c\}$ , then  $c \circ (b \circ c) = c \circ c \subseteq I$ . Since  $I$  is a weak implicative hyper *BCK*-ideal of  $H$ , then by Theorem 3.3,  $c \in I$  which is impossible. If  $b \circ c = \{a, c\}$ , then  $(b \circ a) \circ c = (b \circ c) \circ a = \{0, c\}$ .



Now,  $(b \circ a) \cap \{0, b\} = \emptyset$ . Since  $0 \in \{0\} = a \circ b$  then  $0 \notin b \circ a$ . Moreover, if  $b \in b \circ a$ , then  $a \in b \circ c \subseteq (b \circ a) \circ c = \{0, c\}$  which is impossible. Hence  $b \circ a = \{a\}$  or  $\{c\}$  or  $\{a, c\}$ . If  $b \circ a = \{a\}$ , then  $\{0\} = (b \circ a) \circ c = \{0, c\}$  which is a impossible. If  $b \circ a = \{c\}$  or  $\{a, c\}$ , then  $\{0, c\} = \{0\} \cup \{c\} = (a \circ a) \cup (c \circ a) = \{a, c\} \circ a = (b \circ c) \circ a = (b \circ a) \circ c = c \circ c \subseteq I$ , which is impossible. Thus,  $I$  is a positive implicative hyper BCK-ideal of type 3.

Case 2.  $b \in x \circ z$

The proof is similar to the proof of Case 1, by the some modification.  $\square$

**Example 3.8.** Let  $H = \{0, a, b, c\}$ . Consider the following tables:

$\circ_1$	0	a	b	c
0	{0}	{0}	{0}	{0}
a	{a}	{0}	{0}	{0}
b	{b}	{a}	{0}	{a}
c	{c}	{c}	{0, c}	{0, c}

$\circ_2$	0	a	b	c
0	{0}	{0}	{0}	{0}
a	{a}	{0}	{0}	{0}
b	{b}	{b}	{0}	{0}
c	{c}	{c}	{c}	{0, c}

Thus  $(H, \circ_1)$  and  $(H, \circ_2)$  are hyper BCK-algebras such that  $a \circ x = \{0\}$  for all  $0 \neq x \in H$ . It is easy to check that  $I_1 = \{0, a, b\}$  is a weak implicative hyper BCK-ideal of  $(H, \circ_1)$  but it is not a hyper BCK-ideal of  $(H, \circ_1)$  (since  $c \circ b = \{0, c\} \ll \{0, a, b\} = I_1$  and  $b \in I_1$  but  $c \notin I_1$ ) and so it is not a positive implicative hyper BCK-ideal of type 3 in  $(H, \circ_1)$ . Therefore, the hyper BCK-ideal condition is necessary in Theorem 3.7. Moreover,  $I_2 = \{0, a\}$  is a positive implicative hyper BCK-ideal of type 3 in  $(H, \circ_2)$  but it is not a weak implicative hyper BCK-ideal. Since,  $(b \circ a) \circ (c \circ b) = \{0\} \subseteq I_2$  and  $a \in I_2$  but  $b \notin I_2$ . Therefore, the converse of the Theorem 3.7 is not correct in general.

**Definition 3.9.** Let  $I$  be a non-empty subset of  $H$ . Then,

- (i)  $I$  is said to be an *implicative hyper BCK-ideal* of  $H$  if  $0 \in I$  and for all  $x, y, z \in H$ ,  $(x \circ z) \circ (y \circ x) \ll I$  and  $z \in I$  imply  $x \in I$ ,
- (ii)  $H$  is called an *implicative hyper BCK-algebra* if  $x \ll x \circ (y \circ x)$ , for all  $x, y \in H$ .

It is easy to check that  $H$  is an implicative hyper BCK-algebra if and only if  $x \in x \circ (y \circ x)$ , for all  $x, y \in H$ .

**Theorem 3.10.** *Every implicative hyper BCK-ideal of  $H$  is a weak implicative hyper BCK-ideal of  $H$ .*

*Proof.* The proof is straightforward.  $\square$

**Example 3.11.** Consider the following table on  $H = \{0, a, b\}$ :

$\circ$	0	a	b
0	{0}	{0}	{0}
a	{a}	{0, a}	{0, a}
b	{b}	{a}	{0, a}

Then  $(H, \circ)$  is hyper *BCK*-algebra. We can see that  $I = \{0, b\}$  is a weak implicative hyper *BCK*-ideal of  $H$ , but it is not an implicative hyper *BCK*-ideal of  $H$ . Because,  $(a \circ 0) \circ (a \circ a) = a \circ \{0, a\} = \{0, a\} \ll \{0, b\} = I$  and  $0 \in I$ , but  $a \notin I$ .

**Theorem 3.12.** [8] *Let  $I$  be a non-empty subset of  $H$ . Then,*

- (i) *if  $I$  is an implicative hyper *BCK*-ideal of  $H$ , then it is a hyper *BCK*-ideal of  $H$ ,*
- (ii) *if  $I$  is a hyper *BCK*-ideal of  $H$ , then  $I$  is an implicative hyper *BCK*-ideal of  $H$  if and only if  $x \circ (y \circ x) \ll I$  implies that  $x \in I$ , for all  $x, y \in H$ .*

**Corollary 3.13.** *Let  $H = \{0, a, b, c\}$  be a hyper *BCK*-algebra such that  $a \circ x = \{0\}$ , for all  $0 \neq x \in H$  and  $I$  be a proper subset of  $H$ . If  $I$  is an implicative hyper *BCK*-ideal of  $H$ , then  $I$  is a positive implicative hyper *BCK*-ideal of type 3.*

*Proof.* Since every implicative hyper *BCK*-ideal of  $H$  is a weak implicative and a hyper *BCK*-ideal, then the proof follows by Theorem 3.7.  $\square$

**Theorem 3.14.** *Let  $H$  be a positive implicative and an implicative hyper *BCK*-algebra and  $I$  be a non-empty subset of  $H$ . Then the following statements are equivalent:*

- (i)  *$I$  is a (weak) hyper *BCK*-ideal of  $H$ ,*
- (ii)  *$I$  is a positive implicative hyper *BCK*-ideal of type 3 (type 1) of  $H$ ,*
- (iii)  *$I_a$  is a (weak) implicative hyper *BCK*-ideal of  $H$ , for all  $a \in H$ ,*
- (iv)  *$I$  is a (weak) implicative hyper *BCK*-ideal of  $H$ .*

*Proof.* (i)  $\Rightarrow$  (ii) The proof follows from Theorem 3.6 of [1] and Theorem 2.4(ii).

(ii)  $\Rightarrow$  (iii) Since  $I$  is a positive implicative hyper *BCK*-ideal of type 3 (type 1), then by Theorem 2.4,  $I_a$  is a (weak) hyper *BCK*-ideal of  $H$ . Now, let  $a \in H$  and  $(x \circ (y \circ x) \subseteq I_a)$   $x \circ (y \circ x) \ll I_a$ , for  $x, y \in H$ . Since  $H$  is an implicative hyper *BCK*-algebra, then  $x \in I_a$  and so  $I_a$  is an (weak) implicative hyper *BCK*-ideal of  $H$ .

(iii)  $\Rightarrow$  (iv) Since  $I_0 = I$ , it is enough set  $a = 0$ .

(iv)  $\Rightarrow$  (i) The proof follows from Theorem 3.3.  $\square$

**Example 3.15.** (i) Let  $H = \{0, a, b, c\}$ . Consider the following table:

$\circ$	0	a	b	c
0	{0}	{0}	{0}	{0}
a	{a}	{0}	{0}	{0}
b	{b}	{b}	{0}	{0}
c	{c}	{c}	{b}	{0, b}

Then  $(H, \circ)$  is a hyper BCK-algebra which it is not a positive implicative hyper BCK-algebra. Since  $(c \circ b) \circ b \neq (c \circ b) \circ (b \circ b)$ . Now,  $I = \{0, a\}$  is a (weak) hyper BCK-ideal of  $H$  but it is not a positive implicative hyper BCK-ideal of type 1 (and so it is not of type 3). Because  $(c \circ b) \circ c = \{0\} \subseteq \{0, a\}$  and  $b \circ c = \{0\} \subseteq \{0, a\}$  but  $c \circ c = \{0, b\} \not\subseteq \{0, a\}$ . Therefore, the positive implicative hyper BCK-algebra condition is necessary in Theorem 3.14.

(ii) The hyper BCK-algebra in Example 2.2(ii) is not an implicative hyper BCK-algebra. Because,  $b \notin \{0\} = b \circ (0 \circ b)$ . Now,  $I = \{0, a\}$  is a (weak) hyper BCK-ideal of  $H$  but it is not a weak implicative hyper BCK-ideal and so is not an implicative hyper BCK-ideal of  $H$ . Thus, the implicative hyper BCK-algebra condition is necessary in Theorem 3.14.

**Definition 3.16.** Let  $I$  be a non-empty subset of  $H$ . Then  $I$  is called a

- (i) *strong implicative hyper BCK-ideal* of  $H$  if  $0 \in I$  and  $((x \circ z) \circ (y \circ x)) \cap I \neq \emptyset$  and  $z \in I$  imply  $x \in I$
- (ii) *strong positive implicative hyper BCK-ideal* of  $H$  if  $0 \in I$  and  $((x \circ y) \circ z) \cap I \neq \emptyset$  and  $y \circ z \subseteq I$  imply  $x \circ z \subseteq I$

for all  $x, y, z \in H$ .

**Theorem 3.17.** [14]

- (i) *Every strong implicative hyper BCK-ideal of  $H$  is a (strong, implicative) hyper BCK-ideal,*
- (ii) *Every reflexive strong implicative hyper BCK-ideal of  $H$  is a strong positive implicative hyper BCK-ideal .*
- (iii) *Every strong positive implicative hyper BCK-ideal of  $H$  is a (strong hyper BCK-ideal ) positive implicative hyper BCK-ideal of type 3.*

**Theorem 3.18.**

- (i) *Every reflexive implicative hyper BCK-ideal of  $H$  is a strong implicative hyper BCK-ideal,*
- (ii) *Every reflexive positive implicative hyper BCK-ideal of type 3 is a strong positive implicative hyper BCK-ideal .*

- (iii) *Every reflexive implicative hyper BCK-ideal of  $H$  is a positive implicative hyper BCK-ideal of type 3.*

*Proof.* (i) Let  $I$  be a reflexive implicative hyper BCK-ideal of  $H$ ,  $((x \circ (y \circ x) \circ z) \cap I = ((x \circ z) \circ (y \circ x)) \cap I \neq \emptyset$  and  $z \in I$ , for  $x, y, z \in H$ . Then, there is  $u \in x \circ (y \circ x)$  such that  $(u \circ z) \cap I \neq \emptyset$  and  $z \in I$ . Since  $I$  is a reflexive hyper BCK-ideal of  $H$  and so is a strong hyper BCK-ideal of  $H$ , then  $u \in I$ . This implies that  $(x \circ (y \circ x)) \cap I \neq \emptyset$  and so by Lemma 2.5,  $x \circ (y \circ x) \ll I$  and since  $I$  is an implicative hyper BCK-ideal, then  $x \in I$ . Therefore,  $I$  is a strong implicative hyper BCK-ideal of  $H$ .

(ii) Let  $I$  be a reflexive positive implicative hyper BCK-ideal of type 3,  $((x \circ y) \circ z) \cap I \neq \emptyset$  and  $y \circ z \subseteq I$ , for  $x, y, z \in H$ . Then by Lemma 2.5(iv),  $(x \circ y) \circ z \ll I$  and  $y \circ z \subseteq I$ . Since  $I$  is a positive implicative hyper BCK-ideal of type 3, then  $x \circ z \subseteq I$ , which implies that  $I$  is a strong positive implicative hyper BCK-ideal of  $H$ .

- (iii) The proof follows from (i), Theorem 3.17(ii) and (iii)  $\square$

**Theorem 3.19.** *Let  $H$  be an implicative hyper BCK-algebra and  $I$  be a non-empty subset of  $H$ . Then  $I$  is a (weak) hyper BCK-ideal of  $H$  if and only if it is a (weak) implicative hyper BCK-ideal of  $H$ .*

*Proof.* By Theorems 3.3 and 3.12, any (weak) implicative hyper BCK-ideal of  $H$  is a (weak) hyper BCK-ideal of  $H$ . Conversely, let  $I$  be a (weak) hyper BCK-ideal of  $H$  and  $(x \circ (y \circ x) \subseteq I) x \circ (y \circ x) \ll I$ . Since  $H$  is an implicative hyper BCK-algebra, then  $(x \in x \circ (y \circ x) \subseteq I) x \in x \circ (y \circ x) \ll I$ . Hence, by Lemma 2.5(i), Theorems 3.3 and 3.12(iii)  $I$  is a (weak) implicative hyper BCK-ideal of  $H$ .  $\square$

**Corollary 3.20.** *Let  $H$  be an implicative hyper BCK-algebra. Then,*

- (i) *every commutative hyper BCK-ideal of type 3 (type 1) is an implicative (weak implicative) hyper BCK-ideal of  $H$ ,*  
(ii) *every reflexive commutative hyper BCK-ideal of type 3 is a positive implicative hyper BCK-ideal of type 3.*

*Proof.* (i) Since every commutative hyper BCK-ideal of type 3 (type 1) is a (weak) hyper BCK-ideal of  $H$ , then the proof follows from Theorem 3.19.

- (ii) The proof follows from (i), Theorems 3.18(i), 3.17(ii) and (iii).  $\square$

**Example 3.21.** Let  $(H, \circ_1)$  be hyper BCK-algebra which is defined in Example 3.8. Then,  $I = \{0, a, b\}$  is a commutative hyper BCK-ideal of type 3 but it is not an implicative hyper BCK-ideal of  $H$ . Because,  $c \notin I$

but for all  $z \in I$  and  $y \in H$ ,  $(c \circ z) \circ (y \circ c) \subseteq \{0, c\} \ll I$ . Moreover,  $H$  is not an implicative hyper BCK-algebra because,  $a \notin \{0\} = a \circ (c \circ a)$ . Thus the implicative hyper BCK-algebra condition is necessary in Corollary 3.20.

**Corollary 3.22.** *Let  $H = \{0, a, b\}$  be a hyper BCK-algebra of order 3 and  $I$  be a non-empty subset of  $H$ . Then,*

- (i)  *$I$  is an implicative hyper BCK-ideal of  $H$  if and only if  $I$  is a hyper BCK-ideal of  $H$ ,*
- (ii)  *$I$  is an implicative hyper BCK-ideal of  $H$  if and only if  $I$  is a positive implicative hyper BCK-ideal of type 3 of  $H$ ,*
- (iii)  *$I$  is an implicative hyper BCK-ideal of  $H$  if and only if it is a commutative hyper BCK-ideal of type 3,*
- (iv) *there are only 16 non-isomorphic hyper BCK-algebra of order 3 such that each of them has at least one proper (commutative hyper BCK-ideal of type 3) implicative hyper BCK-ideal.*

*Proof.* (i) ( $\Rightarrow$ ) The proof follows by Theorem 3.12(i).

( $\Leftarrow$ ) By Theorem 3.12(ii) it is enough to show that  $x \circ (y \circ x) \ll I$  implies  $x \in I$ , for all  $x, y \in H$ . Now, by considering Lemmas 2.5(i) and Lemma 2.6 of [1], the proof is similar to the proof of Theorem 3.5.

(ii) The proof follows by (i) and Theorem 3.10 of [1].

(iii) The proof follows from (i) and Theorem 4.6(i) of [1].

(iv) The proof follows by (i), (iii) and Theorem 3.14 of [2].  $\square$

## 4. Conclusion

**Theorem 3.23.**

- (i) *The following diagram hold for any hyper BCK-algebras:*

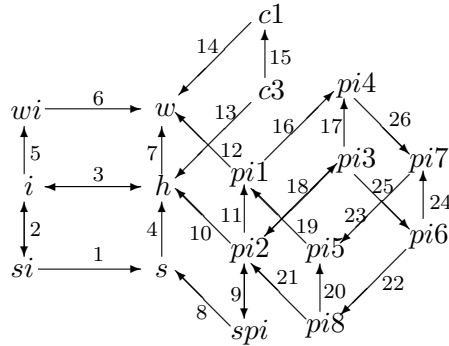

(ii) the following diagram hold for any hyper BCK-algebras of order 3:

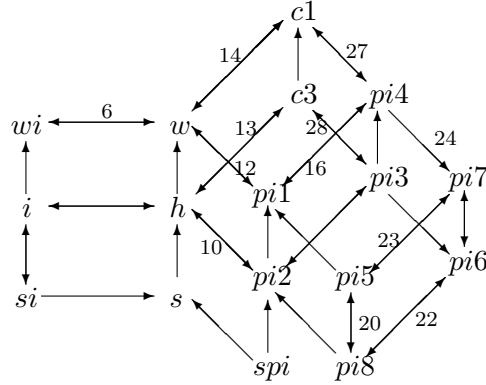

where,

- c1 commutative hyper BCK-ideal of type 1
- c3 commutative hyper BCK-ideal of type 3
- pij positive implicative hyper BCK-ideal of type j (j = 1, ..., 8)
- spi strong positive implicative hyper BCK-ideal
- h hyper BCK-ideal
- s strong hyper BCK-ideal
- w weak hyper BCK-ideal
- i implicative hyper BCK-ideal
- si strong implicative hyper BCK-ideal
- wi weak implicative hyper BCK-ideal

*Proof.* (i)

Arrow(s)	Reason(s)
1	By Theorem 3.17(i)
2	By Theorems 3.17(i) and 3.18(i)
3	By Theorems 3.12(i) and 3.19
4, 7, 10, 12, 13, 14	Remark before Theorem 2.4
5	By Theorem 3.10
6	By Theorem 3.3
8, 9	By Theorems 3.17(iii) and 3.18(ii)
11, 16, 17, ..., 26	See Ref. [2]
15	See Ref. [1]

(ii)

Arrow(s)	Reason(s)
6	By Theorem 3.5
10, 12, 16, 20, 22, 23, 24	See Ref. [2]
13, 14, 27, 28	See Ref. [1]

□

## Open problems

- (i) *Under what condition(s), a weak implicative hyper BCK-ideal is an implicative hyper BCK-ideal ?*
- (ii) *By Theorem 3.5, the notions of weak hyper BCK-ideal and weak implicative hyper BCK-ideal are equivalent in any hyper BCK-algebras of order 3. Is it correct this theorem in any hyper BCK-algebras of order greater than 3 ?*

## References

- [1] **R. A. Borzooei, M. Bakhshi:** *Some results on hyper BCK-algebras*, Quasi-groups and Related Systems **11** (2004), 9 – 24.
- [2] **R. A. Borzooei, M. Bakhshi:** *On positive implicative hyper BCK-ideals*, Sci. Math. Japonicae (2004), to appear.
- [3] **R. A. Borzooei, P. Corsini, M. M. Zahedi:** *Some kinds of positive implicative hyper K-ideals*, Discrete Math. Sci. Cryptography, **6** (2003), 97 – 108.
- [4] **R. A. Borzooei, M. M. Zahedi, H. Rezaei:** *Classification of hyper BCK-algebras of order 3*, Italian J. Pure Appl. Math. **12** (2002), 175 – 184.
- [5] **R. A. Borzooei, M. M. Zahedi:** *Positive implicative hyper K-ideals*, Sci. Math. Japonicae **53** (2001), 525 – 533.
- [6] **P. Corsini, V. Leoreanu:** *Applications of hyperstructures theory*, Advanced in Mathematics, Kluwer Academic Publishers, 2003.
- [7] **Y. Imai, K. Iséki:** *On axiom systems of propositional calculi*, XIV Proc. Japan Academy **42** (1966), 19 – 22.
- [8] **Y. B. Jun, X. L. Xin:** *Implicative hyper BCK-ideals of hyper BCK-algebras*, Math. Japonicae **52** (2000), 435 – 443.
- [9] **Y. B. Jun, X. L. Xin:** *Scalar elements and hyperatoms of hyper BCK-algebras*, Sci. Math. **2** (1999), 303 – 309.
- [10] **Y. B. Jun, X. L. Xin:** *Positive implicative hyper BCK-algebras*, Sci. Math. Japonicae **55** (2002), 97 – 106.
- [11] **Y. B. Jun, X. L. Xin, E. H. Roh, M. M. Zahedi:** *Strong hyper BCK-ideals of hyper BCK-algebras*, Math. Japonicae **51** (2000), 493 – 498.
- [12] **Y. B. Jun, M. M. Zahedi, X. L. Xin, R. A. Borzooei:** *On hyper BCK-algebras*, Italian J. Pure Applied Math. **8** (2000), 127 – 136.
- [13] **F. Marty:** *Sur une generalization de la notion de groups*, 8th congress Math. Scandinaves, Stockholm, (1934), 45 – 49.

- [14] **E. H. Roh, Q. Zhang, Y. B. Jun:** *Some results in hyper BCK-algebras*,  
Sci. Math. Japonicae **55** (2002), 297 – 304.

Department of Mathematics  
Sistan and Baluchestan University  
Zahedan  
Iran  
e-mail: borzooei@hamoon.usb.ac.ir,  
mbakhshi@hamoon.usb.ac.ir

Received November 14, 2003

Revised January 16, 2004